

Autonics

Photoelectric Sensor

BX SERIES

INSTRUCTION MANUAL



Thank you for choosing our Autonics product.
Please read the following safety considerations before use.

■ Safety Considerations

※ Please observe all safety considerations for safe and proper product operation to avoid hazards.
※ ⚠ symbol represents caution due to special circumstances in which hazards may occur.

⚠ Warning Failure to follow these instructions may result in serious injury or death.
⚠ Caution Failure to follow these instructions may result in personal injury or product damage.

⚠ Warning

- Fail-safe device must be installed when using the unit with machinery that may cause serious injury or substantial economic loss. (e.g. nuclear power control, medical equipment, ships, vehicles, railways, aircraft, combustion apparatus, safety equipment, crime/disaster prevention devices, etc.)
Failure to follow this instruction may result in fire, personal injury, or economic loss.
- Do not disassemble or modify the unit.
Failure to follow this instruction may result in electric shock or fire.
- Do not connect, repair, or inspect the unit while connected to a power source.
Failure to follow this instruction may result in electric shock or fire.
- Check 'Connections' before wiring.
Failure to follow this instruction may result in fire.

⚠ Caution

- Use the unit within the rated specifications.
Failure to follow this instruction may result in fire or product damage.
- Use dry cloth to clean the unit, and do not use water or organic solvent.
Failure to follow this instruction may result in electric shock or fire.
- Do not use the unit in the place where flammable/explosive/corrosive gas, humidity, direct sunlight, radiant heat, vibration, impact, or salinity may be present.
Failure to follow this instruction may result in fire or explosion.
- Do not use a load over the range of rated relay specification.
Failure to follow this instruction may result in insulation failure, contact melt, contact failure, relay broken, or fire.

■ Ordering Information

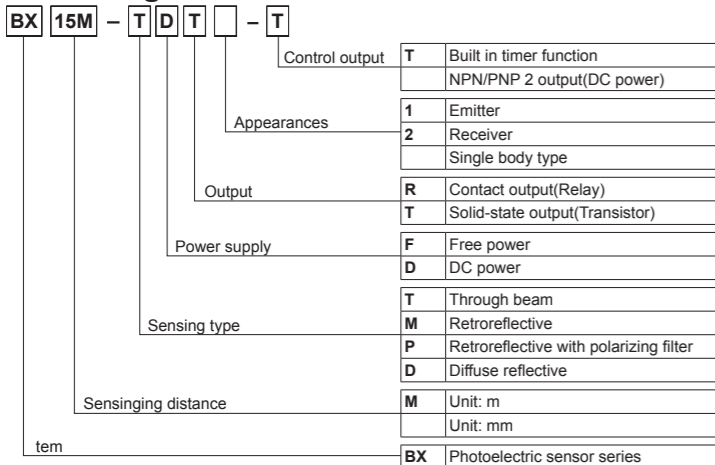

■ Control Output Circuit Diagram

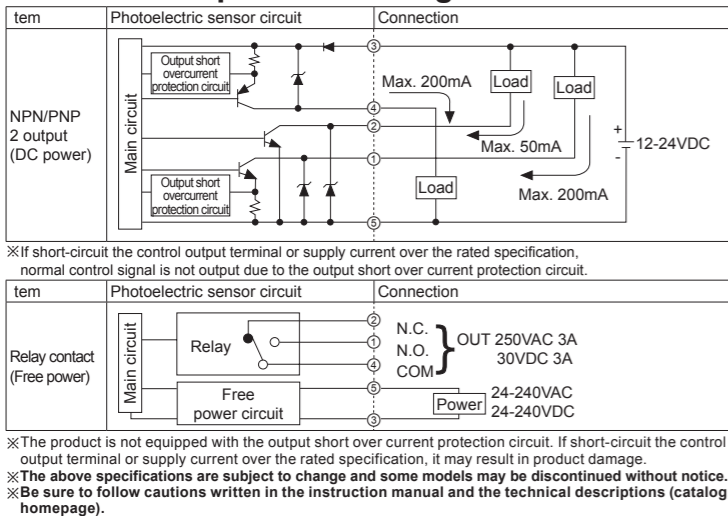

※ The product is not equipped with the output short over current protection circuit. If short-circuit the control output terminal or supply current over the rated specification, it may result in product damage.
※ The above specifications are subject to change and some models may be discontinued without notice.
※ Be sure to follow cautions written in the instruction manual and the technical descriptions (catalog, homepage).

■ Specifications

Type	Free power, relay contact output				DC power, solid state output				
	Through-beam	Retroreflective	Retroreflective (with polarizing filter)	Diffuse reflective	Through-beam	Retroreflective	Retroreflective (with polarizing filter)	Diffuse reflective	
Model	Standard type Built-in Timer	BX15M-TFR BX15M-TFR-T	BX5M-MFR BX5M-MFR-T	BX3M-PFR BX3M-PFR-T	BX700-DFR BX700-DFR-T	BX15M-TDT BX15M-TDT-T	BX5M-MDT BX5M-MDT-T	BX3M-PDT BX3M-PDT-T	BX700-DDT BX700-DDT-T
Sensing distance	15m	0.1 to 5m (reflector MS-2) ^{※1}	0.1 to 2m (reflector MS-2), 0.1 to 3m (reflector MS-3) ^{※1}	700mm ^{※2}	15m	0.1 to 5m (reflector MS-2) ^{※1}	0.1 to 2m (reflector MS-2), 0.1 to 3m (reflector MS-3) ^{※1}	700mm ^{※2}	
Sensing target	Opaque materials of min. Ø15mm	Opaque materials of min. Ø60mm		Translucent, opaque materials	Opaque materials of min. Ø15mm	Opaque materials of min. Ø60mm		Translucent, opaque materials	
Hysteresis	—				Max. 20% at sensing distance				
Response time	Max. 20ms				Max. 1ms				
Power supply	24-240VAC ~ ±10% 50/60Hz, 24-240VDC ±10% (ripple P-P: max. 10%)				12-24VDC ±10% (ripple P-P: max. 10%)				
Power consumption	Max. 3VA				—				
Current consumption	—				Max. 50mA				
Light source	Infrared LED (850nm)		Red LED (660nm)	Infrared LED (940nm)	Infrared LED (850nm)		Red LED (660nm)	Infrared LED (940nm)	
Sensitivity	Sensitivity adjuster								
Operation mode	Selectable Light ON or Dark ON by switch								
Control output	Relay contact output • Relay contact capacity: 30VDC 3A at resistive load, 250VAC ~ 3A at resistive load • Relay contact composition: 1c				NPN or PNP open collector output • Load voltage: max. 30VDC • Load current: max. 200mA • Residual voltage - NPN: max. 1VDC, PNP: max. 2.5VDC				
Self-diagnosis output	Green LED indicator Green LED turns on at unstable operation				NPN open collector output • Load voltage: max. 30VDC • Load current: max. 50mA • Residual voltage: max. 1VDC (load current: 50mA), max. 0.4VDC (load current: 16mA)				
Protection circuit	Reverse polarity protection circuit, output short overcurrent protection circuit								
Timer function	• Selectable ON Delay, OFF Delay, One Shot Delay by slide switch • Delay Time: 0.1 to 5sec (timer adjuster)								
Indication	Operation indicator: yellow LED, stable indicator: green LED								
Connection	Outgoing cable								
Insulation resistance	Min. 20MΩ (at 500VDC megger)								
Insulation type	Double or strong insulation (Mark: □) Dielectric voltage between the measured input and the power: 1.5kV								
Noise strength	±1000V the square wave noise (pulse width: 1μs) by the noise simulator				±240V the square wave noise (pulse width: 1μs) by the noise simulator				
Dielectric strength	1500VAC 50/60Hz for 1minute								
Vibration	1.5mm amplitude at frequency of 10 to 55Hz in each of X, Y, Z directions for 2 hours Malfunction 1.5mm amplitude at frequency of 10 to 55Hz in each of X, Y, Z directions for 10 minutes								
Shock	Mechanical 500m/s ² (approx. 50G) in X, Y, Z directions for 3 times Malfunction 100m/s ² (approx. 10G) in X, Y, Z directions for 3 times								
Environment	Ambient illumination Sunlight: max. 11,000lx, incandescent lamp: max. 3,000lx (receiver illumination) Ambient temperature -20 to 55°C, storage: -25 to 70°C Ambient humidity 35 to 85%RH, storage: 35 to 85%RH								
Protection	IP66 (IEC standard)								
Material	Individual —		Reflector (MS-2)	Reflector (MS-3)	—		Reflector (MS-2)	Reflector (MS-3)	
Accessory	Common —		Adjustment screwdriver, mounting bracket, Z bolt: 2, washer: 2, Ø6 waterproof rubber: 2, Ø10 waterproof rubber: 2	Adjustment screwdriver, mounting bracket, Z bolt: 1, washer: 1, Ø6 waterproof rubber: 1, Ø10 waterproof rubber: 1	—		Adjustment screwdriver, mounting bracket, Z bolt: 1, washer: 1, Ø6 waterproof rubber: 1, Ø10 waterproof rubber: 1	—	
Approval	CE								
Unit weight	TFR: approx. 225g, TFR-T: approx. 226g	MFR: approx. 130g, MFR-T: approx. 131g	PFR: approx. 148g, PFR-T: approx. 149g	DFR: approx. 115g, DFR-T: approx. 116g	TDT: approx. 211g, TDT-T: approx. 212g	MDT: approx. 123g, MDT-T: approx. 124g	PDT: approx. 141g, PDT-T: approx. 142g	DDT: approx. 116g, DDT-T: approx. 117g	

※1: The sensing range of the retroreflective sensor is the possible setting ranges of the reflector. An object can be sensed, although the distance between sensor and target is shorter than 0.1m.
※2: Non-glossy white paper 200×200mm.
※The temperature or humidity mentioned in Environment indicates a non freezing or condensation environment.

■ Connections

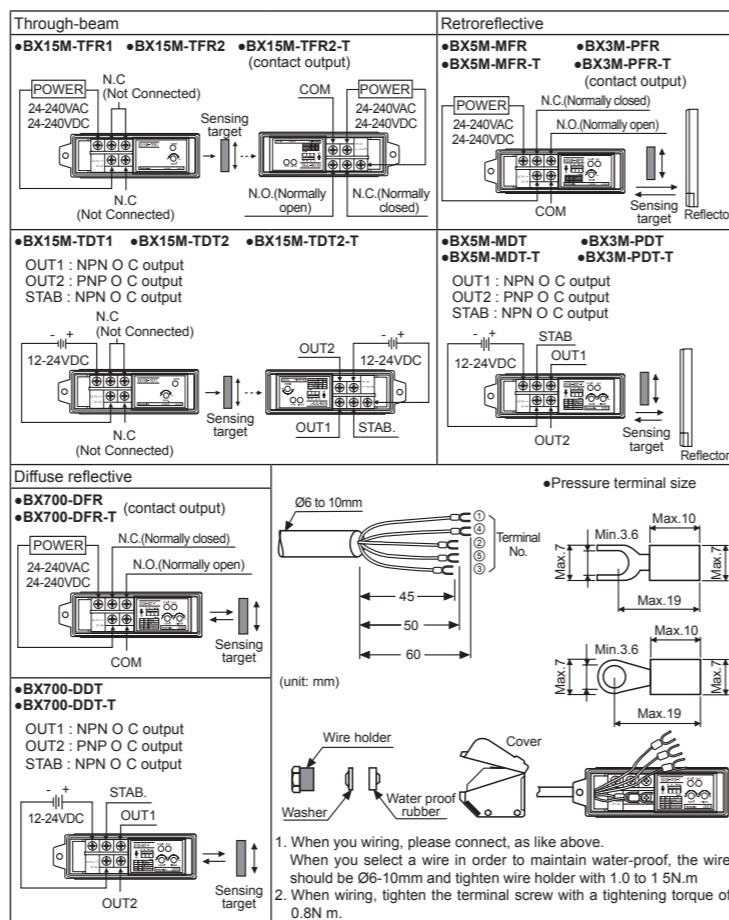

■ Operation Mode

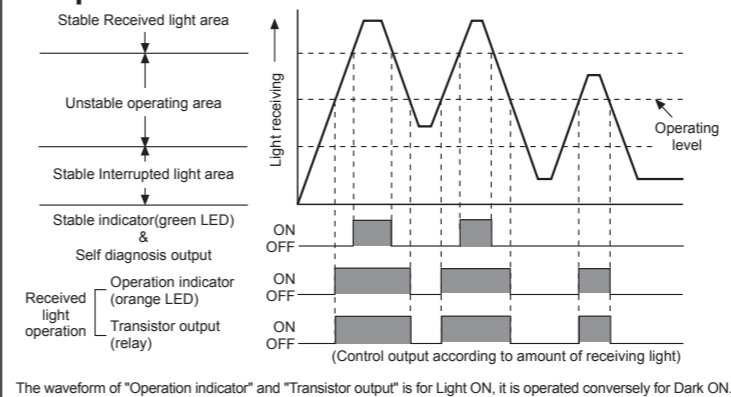

■ Timer Mode

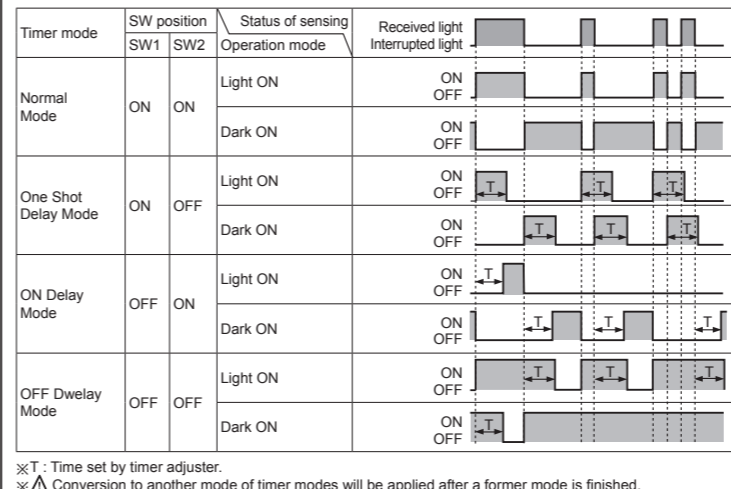

■ Mounting and Adjustment

Use the product with the protective cover in the place.
Failure to follow this instruction may result in electric shock.
When extending wire, use AWG20 cable or over within 100m.
When using photoelectric sensors closely over two units, it may result in malfunction due to mutual interference.
When installing the product, tighten the wire holder with a tightening torque of 1.0 to 1.5N.m.
When installing the cover, tighten the screw with a tightening torque of 0.3 to 0.5 N.m.

○Through-Beam type

- Supply the power to the photoelectric sensor, after setting the emitter and the receiver in face to face.
- Set the receiver in center of position where indicator turns on, as adjusting the receiver or the emitter right and left, up and down.
- Fix both units up tightly after checking that the units senses the target.

※If the sensing target is translucent body or smaller than Ø16mm, it might not sense the target cause light passed.
※Sensitivity adjustment: Please see the diffuse reflective type.

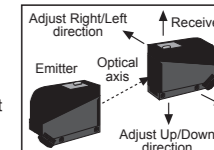

○Retroreflective type

- Supply the power to the photoelectric sensor, after setting the photo sensor and the reflector (MS-2) in face to face.
- Set the photoelectric sensor in the position which indicator turns on, as adjusting the reflector or the sensor right and left, up and down.
- Fix both units tightly after checking that the units sense the target.

※If use more than 2 photo sensors in parallel, the space between them should be more than 30cm.
※If reflectance of target is higher than non-glossy white paper, it might cause malfunction by reflection from the target when the target is near to photo sensor.
Therefore, put enough space between the target and photo sensor or the surface of target should be installed at an angle of 30° to 45° against optical axis. (When sensing target with high reflectance near by, photo sensor with the polarizing filter should be used.)
※Sensitivity adjustment: Please see the diffuse reflective type.

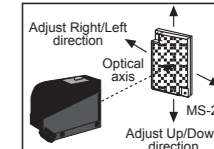

○Retroreflective type (with polarizing filter)

When the beam passes through polarizing filter from emitter, it will be converted as horizontal transverse beam and reaches to reflector MS-2 (MS-3), afterwards it is converted by reflector function as vertical beam and reaches to receiver through polarizing filter. Even it can sense normal reflector.

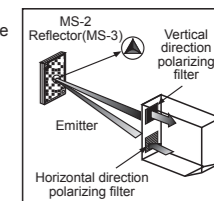
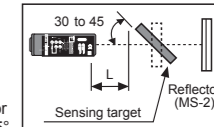

○Diffuse reflective type

- Even though the diffuse reflective type is set at max. sensitive position, the sensitivity of the sensor must be adjusted according to the existence of the reflective material in background.
- Set the target at sensing position and turn sensitivity volume from minimum sensitivity position slowly, confirm ⊙ position where indicator (yellow LED) is ON and self-diagnosis indicator (green LED) is OFF.
- If turning volume higher slowly when a target is removed, the operation indicator (yellow LED) will be OFF and self-diagnosis indicator (green LED) will be ON. Confirm this position as ⊙. [When self-diagnosis indicator (green LED) and operation indicator (yellow LED) are OFF, the max. sensitivity position will be ⊙.]
- Set the adjuster at the center of two switching point ⊙, ⊙.

※Above sensitivity adjustment is when it is the state of Light ON. If it is the state of Dark ON, operation indicator (yellow LED) will be opposite.
※The sensing distance indicated on specification chart is against 200×200mm of non-glossy white paper, may be changed by the size of the target, reflectance of the target.

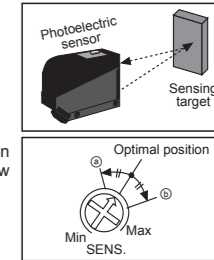

■ Cautions during Use

- Follow instructions in 'Cautions during Use'. Otherwise, it may cause unexpected accidents.
- When connecting a DC relay or other inductive load to the output, remove surge by using diodes or varistors.
- Use the product, 0.5 sec after supplying power.
When using separate power supply for the sensor and load, supply power to sensor first.
- 12-24VDC power supply should be insulated and limited voltage/current or Class 2, SELV power supply device.
- Wire as short as possible and keep away from high voltage lines or power lines, to prevent inductive noise.
- When using switching mode power supply to supply the power, ground F.G. terminal and connect a condenser between 0V and F.G. terminal to remove noise.
- When using sensor with the equipment which generates noise (switching regulator, inverter, servo motor, etc.), ground F.G. terminal of the equipment.
- This unit may be used in the following environments.
⊙ Indoors (in the environment condition rated in 'Specifications')
⊙ Altitude max. 2,000m
⊙ Pollution degree 2
⊙ Installation category II

■ Major Products

- Photoelectric Sensors
- Fiber Optic Sensors
- Door Sensors
- Door Side Sensors
- Area Sensors
- Proximity Sensors
- Pressure Sensors
- Rotary Encoders
- Connectors/Sockets
- Switching Mode Power Supplies
- Control Switches/Lamps/Buzzers
- I/O Terminal Blocks & Cables
- Stepper Motors/Drivers/Motion Controllers
- Graphic/Logic Panels
- Field Network Devices
- Laser Marking System (Fiber, CO₂, Nd: YAG)
- Laser Welding/Cutting System
- Temperature Controllers
- Temperature/Humidity Transducers
- SSRs/Power Controllers
- Counters
- Timers
- Panel Meters
- Tachometer/Pulse (Rate) Meters
- Display Units
- Sensor Controllers